

Technics®

OTTAVA™ S



(Image: SC-C50)

Operating Instructions

Wireless Speaker System

SC-C50 / SC-C30

Music is borderless and timeless, touching people's hearts across cultures and generations.

Each day the discovery of a truly emotive experience from an unencountered sound awaits.

Let us take you on your journey to rediscover music.

Rediscover Music™

Technics

Delivering the Ultimate Emotive Musical Experience to All

At Technics we understand that the listening experience is not purely about technology but the magical and emotional relationship between people and music.

We want people to experience music as it was originally intended and enable them to feel the emotional impact that enthuses and delights them.

Through delivering this experience we want to support the development and enjoyment of the world's many musical cultures. This is our philosophy.

With a combination of our love of music and the vast high-end audio experience of the Technics team, we stand committed to building a brand that provides the ultimate emotive musical experience by music lovers, for music lovers.

Director
Michiko Ogawa

A handwritten signature in black ink, reading "Michiko Ogawa". The signature is fluid and cursive, with a long horizontal flourish extending to the right.

Thank you for purchasing this product.

Please read these instructions carefully before using this product, and save this manual for future use.

- About descriptions in these operating instructions
 - Pages to be referred to are indicated as “⇒ ○○”.
 - The illustrations shown may differ from your unit.

Sales and Support Information

Customer Communications Centre

- For customers within the UK: 0333 222 8777
- For customers within Ireland: 01 447 5229
- Monday–Friday 9:00 am – 5:00 pm, (Excluding public holidays).
- For further support on your product, please visit our website: www.technics.com/uk/

Features

Amazingly clear and deep sound
in room-filling soundstage

Speakers are optimally positioned in its compact, arc form design. These are powerfully driven by a 2.1-channel full digital amp to obtain room-filling Hi-Fi sound.

Optimising sound for any music
listening environment

Space Tune™ optimises the sound no matter where it is placed or where you are listening. A built-in microphone enables a new Auto function to optimise the listening environment from the main unit or a smartphone app with a simple operation.

Broad selection of streaming
services, easy-to-use controls

An easy-to-use connectivity supports USB, analogue input (AUX), optical input, AirPlay, Bluetooth®, Chromecast built-in, Spotify, TIDAL, Deezer, internet radio and Network Playback (access stored music), allowing comfortable playback of a diverse range of music sources from a single unit.

Table of contents

Read first	06
------------	----

Please carefully read the “Safety precautions” of this manual before use.

Control reference guide	15
-------------------------	----

This unit (front/top/rear)

Connections	20
-------------	----

AC mains lead connection, Network settings

Operations	30
------------	----

Streaming online music, etc.

Settings	48
----------	----

Favourite function, Other settings

Others	52
--------	----

Troubleshooting, Specifications, etc.

Accessories

AC mains lead (1)
K2CT3DR00009

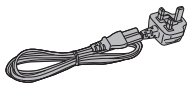

- The smartphone on the cover page is not supplied with this unit.
- Product numbers provided in these operating instructions are correct as of August 2019.
- These may be subject to change.
- Do not use AC mains lead with other equipment.

Read first

Safety precautions.....	07
Warning	07
Caution	07
Installation	12
Installation	12
Notes on the speakers.....	12
For optimum sound effects	12
Unit care	13
Using “Technics Audio Center”	13
Firmware updates	13
To dispose of or transfer this unit	14

🔄 Table of contents ... 04

Safety precautions

Warning

Unit

- To reduce the risk of fire, electric shock or product damage,
 - Do not expose this unit to rain, moisture, dripping or splashing.
 - Do not place objects filled with liquids, such as vases, on this unit.
 - Use the recommended accessories.
 - Do not remove covers.
 - Do not repair this unit by yourself. Refer servicing to qualified service personnel.
 - Do not let metal objects fall inside this unit.
 - Do not place heavy items on this unit.

AC mains lead

- To reduce the risk of fire, electric shock or product damage,
 - Ensure that the power supply voltage corresponds to the voltage printed on this unit.
 - Insert the mains plug fully into the socket outlet.
 - Do not pull, bend, or place heavy items on the lead.
 - Do not handle the plug with wet hands.
 - Hold onto the mains plug body when disconnecting the plug.
 - Do not use a damaged mains plug or socket outlet.
- The mains plug is the disconnecting device. Install this unit so that the mains plug can be unplugged from the socket outlet immediately.
- Ensure the earth pin on the mains plug is securely connected to prevent electrical shock.
 - An apparatus with CLASS I construction shall be connected to a mains socket outlet with a protective earth connection.

Caution

Unit

- Do not place sources of naked flames, such as lighted candles, on this unit.
- This unit may receive radio interference caused by mobile telephones during use. If such interference occurs, please increase separation between this unit and the mobile telephone.
- This unit is intended for use in moderate and tropical climates.
- Do not put any objects on this unit. This unit becomes hot while it is on.

Placement

- Place this unit on an even surface.
- To reduce the risk of fire, electric shock or product damage,
 - Do not install or place this unit in a bookcase, built-in cabinet or in another confined space. Ensure this unit is well ventilated.
 - Do not obstruct this unit's ventilation openings with newspapers, tablecloths, curtains, and similar items.
 - Do not expose this unit to direct sunlight, high temperatures, high humidity, and excessive vibration.
- Keep magnetised items away. Magnetised cards, watches, etc., can be damaged if placed too close to this system.

Caution for AC Mains Lead

(For the AC mains plug of three pins)

For your safety, please read the following text carefully.

This appliance is supplied with a moulded three pin mains plug for your safety and convenience.

A 3-ampere fuse is fitted in this plug.

Should the fuse need to be replaced please ensure that the replacement fuse has a rating of 3-ampere and that it is approved by ASTA or BSI to BS1362.

Check for the ASTA mark  or the BSI mark  on the body of the fuse.

If the plug contains a removable fuse cover you must ensure that it is refitted when the fuse is replaced.

If you lose the fuse cover the plug must not be used until a replacement cover is obtained.

A replacement fuse cover can be purchased from your local dealer.

Before use

Remove the connector cover.

How to replace the fuse

The location of the fuse differ according to the type of AC mains plug (figures A and B). Confirm the AC mains plug fitted and follow the instructions below. Illustrations may differ from actual AC mains plug.

1. Open the fuse cover with a screwdriver.

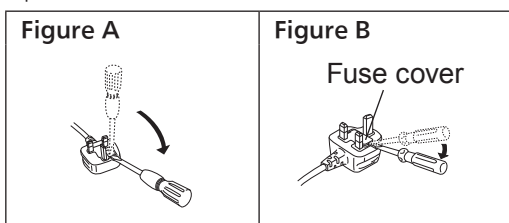

2. Replace the fuse and close or attach the fuse cover.

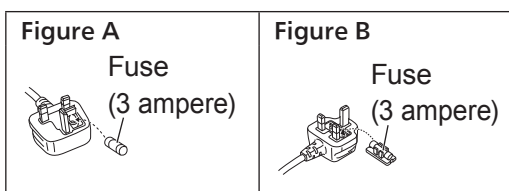

Panasonic Corporation, a company having its registered office of 1006, Oaza Kadoma, Kadoma City, Osaka 571-8501, Japan, automatically collects personal data such as IP address and/or Device ID from your device as soon as you connect it to the Internet. We do this to protect our customers and the integrity of our Service as well as to protect the rights or property of Panasonic.

You have a right of access, rectification and objection to in certain circumstances, a right of erasure, restriction of processing, data portability and a right to object to other forms of processing. If you wish to exercise any of the above rights and/or wish to know more about the processing of your personal data in this context, please refer to the full text of our privacy policy displayed at the support page of your device, <http://panasonic.jp/support/global/cs/audio/>, <http://www.technics.com/support/> or contact our customer communications/support number or address described in the Pan European Guarantee included in your device box to send you the full text of our privacy policy.

Disposal of Old Equipment Only for European Union and countries with recycling systems



This symbol on the products, packaging, and/or accompanying documents means that used electrical and electronic products must not be mixed with general household waste.

For proper treatment, recovery and recycling of old products, please take them to applicable collection points in accordance with your national legislation.

By disposing of them correctly, you will help to save valuable resources and prevent any potential negative effects on human health and the environment.

For more information about collection and recycling, please contact your local municipality. Penalties may be applicable for incorrect disposal of this waste, in accordance with national legislation.

Declaration of Conformity (DoC)

Hereby, "Panasonic Corporation" declares that this product is in compliance with the essential requirements and other relevant provisions of Directive 2014/53/EU.

Customers can download a copy of the original DoC to our RE products from our DoC server:

<http://www.ptc.panasonic.eu>

Contact to Authorised Representative:

Panasonic Marketing Europe GmbH, Panasonic Testing Centre, Winsbergring 15, 22525 Hamburg, Germany

Type of wireless	Frequency band	Maximum power (dBm e.i.r.p.)
WLAN	2412 - 2472 MHz	20 dBm
	5180 - 5320 MHz	20 dBm
	5500 - 5700 MHz	20 dBm
Bluetooth®	2402 - 2480 MHz	10 dBm

5.15 - 5.35 GHz band is restricted to indoor operations only in the following countries.

AT	BE	BG	CZ	DK	EE	FR	DE	IS	IE	IT
EL	ES	CY	LV	LI	LT	LU	HU	MT	NL	NO
PL	PT	RO	SI	SK	TR	FI	SE	CH	UK	HR

Product Identification Marking is located on the bottom of the unit.

Installation

Installation

- Turn off all the equipment before connection and read the appropriate operating instructions. Be sure to raise this unit when moving, and do not drag this unit.

Notes on the speakers

- These speakers do not have magnetic shielding. Do not place them near TV, PC or other equipment easily influenced by magnetism.
- Playing music at high volumes for a long period can cause damage to the system and shorten the life of the system.
- Decrease the volume in the following conditions to prevent damage.
 - When playing distorted sound
 - When adjusting the sound quality
 - When turning on/off this unit

For optimum sound effects

The quality and volume of the bass sound, sound localisation performance, sound ambience, etc. will change depending on the installation location of this unit, listening position, room conditions, and other factors. Refer to the information below when installing this unit.

Determining the installation location

- Place this unit on a flat safe surface.

Adjusting the distances between this unit and the wall

- If you install this unit close to a wall or a corner, the bass sound will be more powerful, however, if the unit is too close to it, sound localisation performance and sound ambience may deteriorate.

Adjusting with the Space Tune function

You can adjust the sound quality automatically according to the installation location (near the wall or the corner of the room).

- ① Press and hold [▶/||] for 5 seconds.
 - “Space Tune (Auto)” is displayed.
- ② Press [▶/||] again while “Space Tune (Auto)” is displayed.
 - A test tone outputs quite big while the measurement is in progress.
 - To cancel the adjustment in the middle, press [↶].
 - When the adjustment is complete, “Success” is displayed.
- ③ Press [↶] to exit the setting.

Unit care

Pull out the AC mains lead from the socket before maintenance. Clean this unit with a soft cloth.

- When dirt is heavy, wring a wet cloth tightly to wipe the dirt, and then wipe it with a soft cloth.
- Do not use solvents including benzine, thinner, alcohol, kitchen detergent, chemical wiper, etc. Doing so may cause the exterior case to be deformed or the coating to come off.

Using “Technics Audio Center”

If you install the dedicated app “Technics Audio Center” (free of charge) on your tablet/smartphone, you can stream music files from the device on your network to this unit, stream online music services, use this unit with other speakers and configure the settings of sound quality, etc.

For details, visit:

www.technics.com/support/

Firmware updates

Occasionally, Panasonic may release updated firmware for this unit that may add or improve the way a feature operates. These updates are available free of charge.

- Refer to “Firmware updates” (⇒ 50) for details on update.

To dispose of or transfer this unit

Before disposing of or transferring this unit, be sure to erase all the recorded information by restoring the settings to factory default. ("To restore all the settings to the factory defaults" (⇒ 53))

- Before you dispose of or transfer this unit to a third party, be sure to log out of your music streaming services accounts to prevent unauthorised use of your accounts.

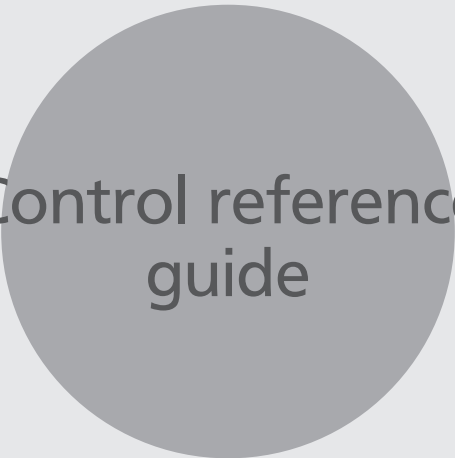

Control reference guide

This unit (front/top)..... 16

This unit (rear)..... 18

[↻ Table of contents ...](#) 04

This unit (front/top)

SC-C50

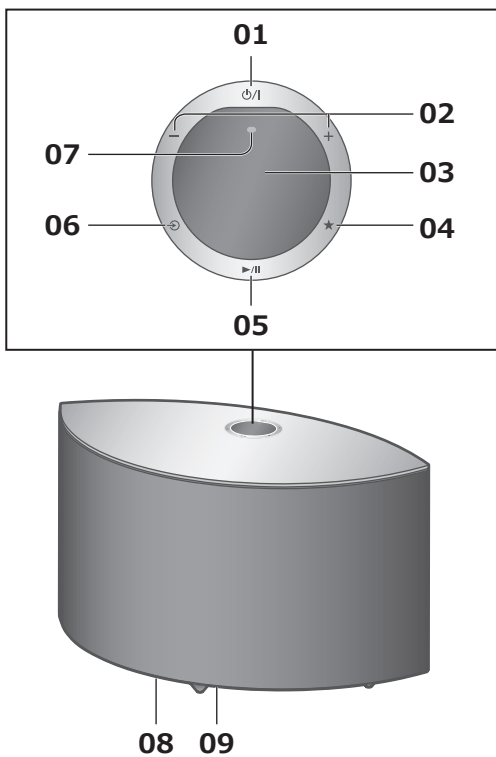

SC-C30

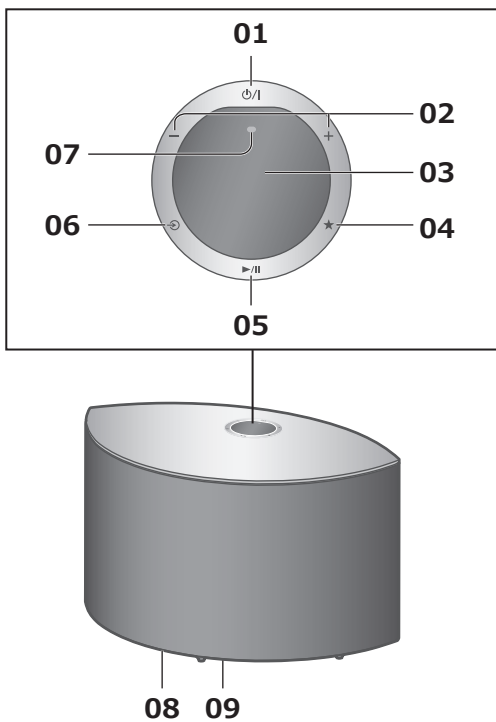

01 [⏻/⏻] Standby/on switch

Press to switch the unit from on to standby mode or vice versa. In standby mode, the unit is still consuming a small amount of power.

02 [–] [+] Adjust volume

- 0 (min) to 100 (max)

03 Display

Input source, etc. are displayed.

04 [★] Favourite

You can register your favourite station or playlist (USB, Podcasts, etc.), and call them.

- You can register up to 9 favourite stations or playlists. To register, press and hold [★] until “Memorised” is displayed while a station tuned in or music is being played back. Then, the station or music is automatically registered to an unused number from 1 to 9.

05 [▶/⏸] Play/Pause

06 [↻] Switch the input source

07 Built-in microphone (for measurement)

08 Product identification marking (Bottom of this unit)

- The model number is indicated.

09 Illumination

Illuminates when the volume is adjusted from the “Technics Audio Center” app, etc.

This unit (rear)

SC-C50

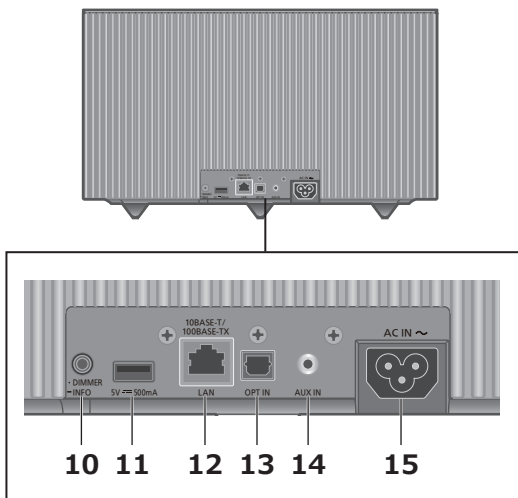

SC-C30

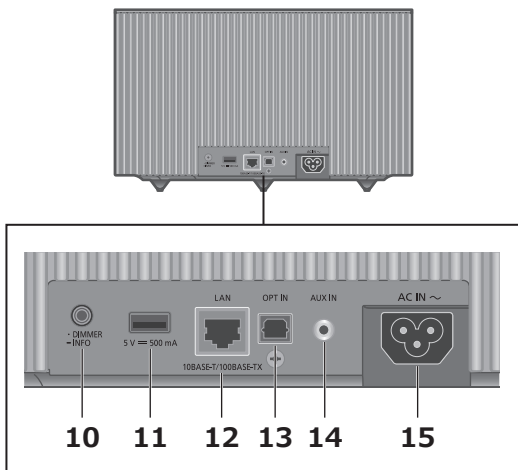

10 [•DIMMER / -INFO]

Adjust the brightness of illumination of the display and bottom of the unit.

- When the display is turned off, it will light up for a few seconds only when you operate this unit. Before the display turns off, "Display Off" will be displayed for a few seconds.
- Press [•DIMMER / -INFO] repeatedly to switch the brightness.
- Press and hold [•DIMMER / -INFO] to display the network status or settings. The displayed items are changed by pressing [•DIMMER / -INFO] repeatedly. (The brightness does not change during this period.)

11 USB-A terminal

(DC 5 V \equiv 500 mA) (\Rightarrow 36)

- If a USB device is connected, [**•DIMMER / -INFO**] is difficult to press. Remove the USB device as necessary.

12 LAN terminal (\Rightarrow 23)

13 Optical digital input terminal (\Rightarrow 33)

14 AUX IN terminal (\Rightarrow 31)

15 AC IN terminal (\sim) (\Rightarrow 21)

Connections

AC mains lead	21
AC mains lead connection	21
Network settings	22
Wired LAN connection	23
Wireless LAN connection	24

[↻ Table of contents ...](#) 04

AC mains lead

SC-C50 is used in the illustrations unless otherwise mentioned.

AC mains lead connection

Connect only after all other connections are completed.

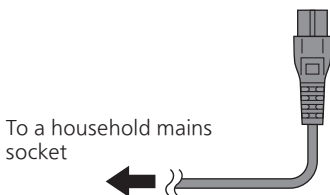
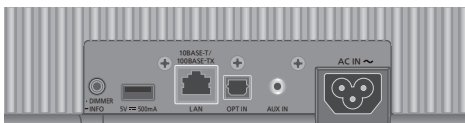

- Use only the supplied AC mains lead.
- Do not connect the AC mains lead until all other connections are complete.
- Insert the plugs of the cables to be connected all the way in.
- Do not bend cables at sharp angles.
- Wireless LAN (Wi-Fi®) setting may start when this unit is turned on. If you stop the Wi-Fi setting, press [↩]. To keep the Wi-Fi setting, start the "Google Home" app and follow the on-screen instructions. (⇒ 22, 24)

Note

- This unit consumes a small amount of AC power (⇒ 66) even when the unit is in standby mode. Remove the plug from the main electrical outlet if you will not be using the unit for an extended period of time. Place the unit so the plug can be easily removed.

Network settings

You can stream online music services or music files from your smartphone/tablet to this unit.

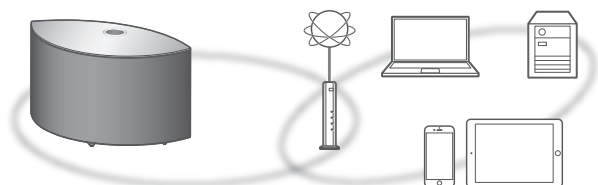

This unit can be connected to a router using a LAN cable or built-in Wi-Fi®.

For a stable connection to the network, a wired LAN connection is recommended.

■ Preparation

If you install the “Google Home” app on your smartphone/tablet, you can set up a connection using the application.

- When using the Chromecast-enabled apps to play music on this unit (⇒ 37), set up a connection using the “Google Home” app.
- Make sure that the Wi-Fi function is activated on your smartphones/tablet.

1 Install the “Google Home” app on your smartphone/tablet.

- To download the “Google Home” app, visit:
<https://www.google.com/cast/setup/>



2 Connect your smartphone/tablet to the same network as this unit before setting.

- Make sure that the network is connected to the Internet.

Wired LAN connection

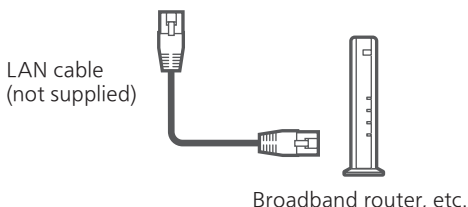
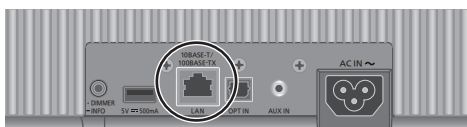

- 1 Disconnect the AC mains lead.**
- 2 Connect this unit to a broadband router, etc. using a LAN cable.**
- 3 Connect the AC mains lead to this unit.**
(⇒ 21)
- 4 Press [⏻/⏻] to turn this unit on.**
- 5 Start the “Google Home” app and follow the on-screen instructions to set up a connection.**

(To use the Chromecast-enabled apps with this unit (⇒ 37))

Note



- While the AC mains lead is disconnected, the LAN cable must be connected or disconnected.
- Use category 7 or above straight LAN cables (STP) when connecting to peripheral devices.
- Inserting any cable other than a LAN cable in the LAN port can damage the unit.
- After turning on this unit, it may take some time until this unit is activated.
- If “Firmware update is available” is displayed after the network connection is set up, the firmware for this unit is available. Press and hold [▶/||] for 5 seconds or longer to start the update. (Press [↶] to cancel the update and an indication disappears.)
 - The progress is displayed as “Updating □ %” while updating. (“□” stands for a number.)
 - When the update has finished successfully, “Success” is displayed. Turn this unit off and on.
- Even when the Wi-Fi function is set to “On”, the wired LAN function is activated while a LAN cable being connected. (“📶” disappears.)

Wireless LAN connection

■ Preparation

- ① Disconnect the AC mains lead.
- ② Disconnect the LAN cable.
- ③ Place this unit as close to the wireless router as possible.
- ④ Connect the AC mains lead to this unit. (⇒ 21)

Note

- After turning on this unit, it may take some time until this unit is activated.
- If “Firmware update is available” is displayed after the network connection is set up, the firmware for this unit is available. Press and hold [▶/||] for 5 seconds or longer to start the update. (Press [↶] to cancel the update and an indication disappears.)
 - The progress is displayed as “Updating □ %” while updating. (“□” stands for a number.)
 - When the update has finished successfully, “Success” is displayed. Turn this unit off and on.
- “” blinks while the network connection is not established. When the network connection is established, “” disappears. The network setting using the “Google Home” app may be available while “” blinks. Start the “Google Home” app and follow the on-screen instructions. (⇒ 28)
- The setting will be cancelled after the set time limit. In that case, try the setting again.
- To cancel this setting in the middle, press [↶] or turn the unit to standby mode.

Network setting for the first time using the “Google Home” app

1 Press [⏻/|] to turn this unit on.

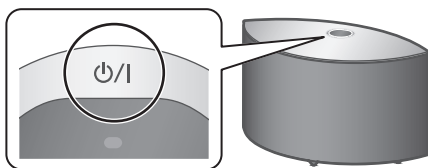

- “Wi-Fi Setup” starts blinking.



2 Start the “Google Home” app and follow the on-screen instructions to set up a connection.

Note

- This unit will be displayed as “Technics-SC-C50-****” (“Technics-SC-C30-****”) if the device name is not set. (“****” stands for characters unique to each set.)
- You can check your network information (SSID, MAC address and IP address) from the “Google Home” app or “Technics Audio Center” app.
- Some items on the “Google Home” app are irrelevant to this unit.
- Press [↵] to cancel the Wi-Fi setting.
- When this unit is turned off and on before the Wi-Fi setting is complete, “Wi-Fi Setup” is displayed again. Perform the Wi-Fi setting or set the Wi-Fi function to “Off” so that it is not displayed thereafter.
- To switch the Wi-Fi function between “On” and “Off”, cancel the Wi-Fi setting, press and hold the volume [—] on the top while pressing [•DIMMER / -INFO] on the rear of this unit for approx. 5 seconds.
- For other connection methods (⇒ 26).

Network setting from the setup menu
(when not using Chromecast-enabled
apps)

Using the WPS button "WPS"

If your wireless router supports WPS, you can set up a connection by pressing the WPS button.

- A compatible wireless router may have the WPS identifier mark.
- Complete the settings within 2 minutes while "WPS" is displayed.

1 Press and hold [↻] (input source switch) on the top while pressing [•DIMMER / -INFO] on the rear of this unit.

- Connection methods (WPS/WPS PIN/Wi-Fi Setup) are displayed in turn.
- The display changes every 5 seconds.
- If "Wi-Fi Setup" blinks after this unit is turned on by pressing [⏻/⏻], press [↻] to hide the "Wi-Fi Setup" screen and try the setting again.

WPS

- If your wireless broadband router supports the WPS (Wi-Fi Protected Setup™) push button

2 Release [↻] and [•DIMMER / -INFO] while "WPS" is displayed.

3 Press the WPS button on the wireless router.

Example:

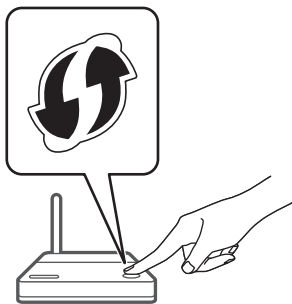

- When the connection is established, "Success" is displayed.
 - "Fail" may be displayed if the connection was not complete. Try this method again from the setup menu. If "Fail" is still displayed, try other methods.

4 Press [▶/||] to exit the setting.

Using the WPS PIN code

“WPS PIN”

If your wireless router supports WPS, you can set up a connection by entering the WPS PIN code.

- For details on how to enter the PIN code, refer to the operating instructions of the wireless router.
- Complete the settings within 2 minutes while “WPS PIN” and the PIN code are displayed.

1 Press and hold [↵] (input source switch) on the top while pressing [•DIMMER / -INFO] on the rear of this unit.

- Connection methods (WPS/WPS PIN/Wi-Fi Setup) are displayed in turn.
- The display changes every 5 seconds.
- If “Wi-Fi Setup” blinks after this unit is turned on by pressing [⏻/⏻], press [↵] to hide the “Wi-Fi Setup” screen and try the setting again.



- If your wireless broadband router support the WPS PIN code method

2 Release [↵] and [•DIMMER / -INFO] while “WPS PIN” is displayed.

3 Enter the displayed PIN code (64428147) into the wireless router from PC, etc.

- When the connection is established, “Success” is displayed.
 - “Fail” may be displayed if the connection was not complete. Try this method again from the setup menu. If “Fail” is still displayed, try other methods.

4 Press [▶/||] to exit the setting.

Note

- When using the Chromecast-enabled apps to play music on this unit (⇒ 37), set up a connection using the “Google Home” app.
- Depending on a router, other connected devices may temporarily lose their connection.
- For details, refer to the operating instructions of the wireless router.

Network setting from the setup menu (when using Chromecast-enabled apps)

Using the “Google Home” app “Wi-Fi Setup”

When using the Chromecast-enabled apps to play music on this unit, you need to set up a network connection using “Google Home” app. When the network has been set up with another method, try the setting again with the following procedure.

1 Press and hold [\rightarrow] (input source switch) on the top while pressing [\bullet DIMMER / -INFO] on the rear of this unit.

- Connection methods (WPS/WPS PIN/Wi-Fi Setup) are displayed in turn.
- The display changes every 5 seconds.
- If “Wi-Fi Setup” blinks after this unit is turned on by pressing [P/I], press [\rightarrow] to hide the “Wi-Fi Setup” screen and try the setting again.

A dark grey circular icon with the text "Wi-Fi Setup" in white.

Wi-Fi
Setup

- When using the “Google Home” app to set up a connection

2 Release [\rightarrow] and [\bullet DIMMER / -INFO] while “Wi-Fi Setup” is displayed.

3 Start the app and follow the on-screen instructions.

- When the connection is established, “Success” is displayed.
 - “Fail” may be displayed if the connection was not complete. Try this method again from the setup menu. If “Fail” is still displayed, try other methods.

4 Press [$\blacktriangleright/\text{III}$] to exit the setting.

Note

- This unit will be displayed as “Technics-SC-C50-****” (“Technics-SC-C30-****”) if the device name is not set. (“****” stands for characters unique to each set.)
- You can check your network information (SSID, MAC address and IP address) from the “Google Home” app or “Technics Audio Center” app.
- Some items on the “Google Home” app are irrelevant to this unit.

Enabling or disabling the wireless LAN function

1 Press and hold the volume [–] on the top while pressing [•DIMMER / -INFO] on the rear of this unit for approx.

5 seconds.

- The Wi-Fi function switches between “On” and “Off”.

Note

- The factory default is “On”.

Operations

Using the auxiliary input.....	31
Adjust the volume level “Input Level”	32
Using digital audio output device	33
Using Bluetooth®	34
Pairing a Bluetooth® device	34
Disconnect the Bluetooth® device	35
Using USB device	36
Streaming music over the network	37
Listening to music using Chromecast-enabled app.....	37
Streaming music files on network devices	39
Playing Internet Radio and Podcasts...	40
Using AirPlay	41
Playing back music using Spotify Connect.....	42
Using TIDAL.....	44
Using Deezer	46

[↶ Table of contents ...](#) 04

Using the auxiliary input

You can connect a portable audio player, etc. with an analogue audio cable ($\phi 3.5$ mm) (not supplied) and play back music.

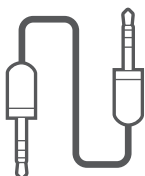
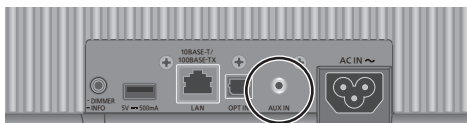

Analogue audio cable ($\phi 3.5$ mm) (not supplied)



Portable audio player, etc.

- 1 Disconnect the AC mains lead.
- 2 Connect this unit and a portable audio player, etc.
- 3 Connect the AC mains lead to this unit.
(\Rightarrow 21)
- 4 Press [Power/I] to turn this unit on.
- 5 Press [Source] repeatedly to select "AUX".
- 6 Start playback on the connected device.

Note

- When enjoying video contents with this function, the video and audio output may not be synchronised.
- Pressing [Play/Pause] mutes the sound while playing back. (To cancel the muting, adjust the volume, press again or turn the unit to standby.)

Adjust the volume level “Input Level”

If sound distortion occurs when using the analogue audio input terminals, setting to “Low” may improve the sound quality.

- 1 Press [↶] to select “AUX”.**
- 2 Press and hold [↶] for 5 seconds.**
- 3 Release [↶] when “Input Level” and “Low” are displayed.**
 - Press and hold [↶] again to set to “High”.

Note

- The factory default is “High”.
- This item can also be set from the dedicated application “Technics Audio Center” (free of charge).

Using digital audio output device

You can connect a CD player, etc. with optical digital audio cable (not supplied) and play back music.

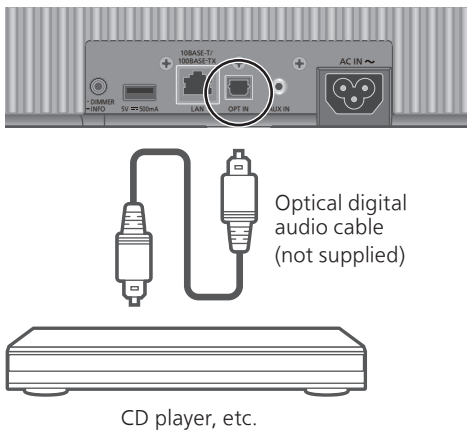

- 1 Disconnect the AC mains lead.
- 2 Connect this unit and a CD player etc.
- 3 Connect the AC mains lead to this unit.
(⇒ 21)
- 4 Press [**⏻/I**] to turn this unit on.
- 5 Press [**↻**] repeatedly to select "OPT".
- 6 Start playback on the connected device.

Note

- When enjoying video contents with this function, the video and audio output may not be synchronised.
- Pressing [**▶/||**] mutes the sound while playing back. (To cancel the muting, adjust the volume, press again or turn the unit to standby.)
- The digital audio input terminal of this unit can only detect the following linear PCM signals. For details, refer to the operating instructions of the connected device.
 - Sampling frequency:
32/44.1/48/88.2/96 kHz
 - Number of quantisation bits:
16/24 bit

Using Bluetooth®

You can listen to the sound from the Bluetooth® audio device from this unit wirelessly.

- Refer to the operating instructions of the Bluetooth® device for details.

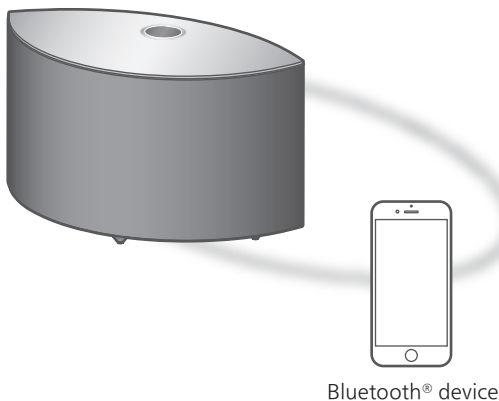

Pairing a Bluetooth® device

■ Preparation

- Turn on this unit, Bluetooth® device and place the device near this unit.
- Turn on the Bluetooth® feature of the device.

■ Registering the Bluetooth® device

- 1 Press [↻] repeatedly to select "📶".**
 - "📶" blinks at 1 second interval when registering for the first time. Proceed to step 3.
- 2 Press and hold [↻] to enter pairing mode.**
 - "📶" blinks at 1 second interval.
- 3 Open the Bluetooth® connection screen, etc. on the Bluetooth® device, and select "Technics-SC-C50-****" ("Technics-SC-C30-****")*1, 2.**
 - If the device name is set on the "Google Home" app, the set name is displayed.
- 4 Play music by operating the Bluetooth® device.**

■ Connecting the paired Bluetooth® device

1 Press [↵] repeatedly to select “”.

- “” blinks per second and this unit tries to connect to the last connected Bluetooth® device. After the connection is complete, proceed to step 3.
- If another Bluetooth® device is already connected with this unit, disconnect from the Bluetooth® device.

2 Open the Bluetooth® connection screen, etc. on the Bluetooth® device, and select “Technics-SC-C50-****” (“Technics-SC-C30-****”)*1, 2.

- If the device name is set on the “Google Home” app, the set name is displayed.

3 Play music by operating the Bluetooth® device.

Note

- If prompted for the passkey, input “0000”.
- You can register up to 8 devices with this unit. If a 9th device is paired, the device that has not been used the longest will be replaced.
- Refer to the operating instructions of the Bluetooth® device for details.

*1: “****” stands for a number that is unique to each set.

*2: The device name can be changed with the dedicated application “Technics Audio Center” (free of charge).

Disconnect the Bluetooth® device

Disconnect from the Bluetooth® device or disconnect by selecting a different input source.

Note

- This unit can only be connected to one device at a time.

Using USB device

You can play back music stored on the connected USB device using the dedicated app “Technics Audio Center” (free of charge) on your tablet/smartphone. For details, visit: www.technics.com/support/

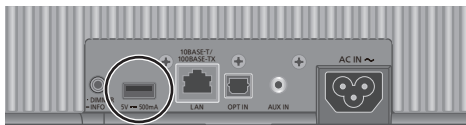

USB device

- 1 **Connect a USB device to the unit.**
- 2 **Press [↵] repeatedly to select “USB”.**
- 3 **Start the dedicated app “Technics Audio Center” on your device (smartphone, tablet, etc.) and play back the music.**
 - Playback also starts by pressing [▶/||] on this unit.

Note

- The unit and USB device become warm when using for a long time. This is not a malfunction.
- The repeat playback, random playback, etc. can be set by using the dedicated application “Technics Audio Center” (free of charge).

Streaming music over the network

Listening to music using Chromecast-enabled app

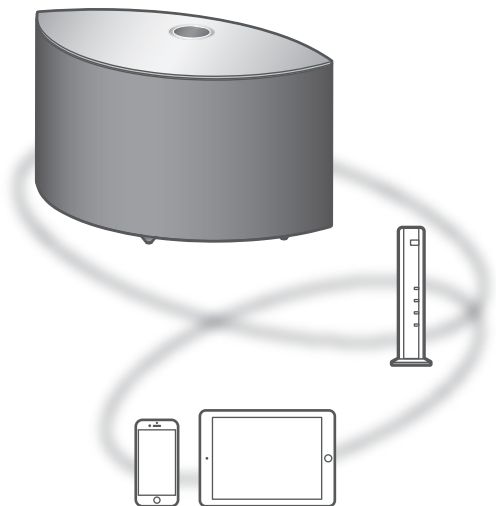

This unit is compatible with Chromecast-enabled apps. For detailed information of Chromecast-enabled apps, visit: g.co/cast/apps

■ Preparation

- Complete the network settings. (⇒ 22)
 - Make sure that the network is connected to the Internet.
- Install a Chromecast-enabled app on your device (smartphone, tablet, etc.).
- Connect the device to the network currently used at home.

1 Start the Chromecast-enabled app on your device (smartphone, tablet, etc.) and select this unit as the connecting device.

- The input source is automatically switched to “Chromecast built-in”.

2 Play back the music.

- “Casting” is displayed.

Not all music streaming services are available in all countries/regions. Registration/subscription may be required, or fees may be charged to use music streaming services. Services are subject to change or be discontinued. For details, visit an individual music streaming service's website.

Important notice:

Before you dispose of or transfer this unit to a third party, be sure to log out of your music streaming services accounts to prevent unauthorised use of your accounts.

Streaming music files on network devices

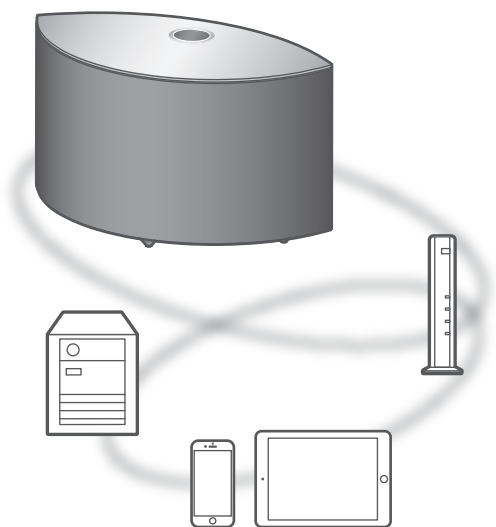

You can stream music files from the device on your network to this unit by using the free app “Technics Audio Center”.

■ Preparation

- Complete the network settings. (⇒ 22)
- Connect the following devices to the same network as this unit.
 - Device with “Technics Audio Center” app installed
 - Device containing music source

1 Install the free app “Technics Audio Center” on your smartphone, tablet, etc.

- Download and install the app from the website below.
www.technics.com/support/

2 Start the app “Technics Audio Center”.

- Always use the latest version of the app.

3 Select this unit as the output speaker.

4 Select a music source.

5 Select a music file.

- The input source to be displayed varies depending on the content.
 - If playing back files stored in the media server, “DMR” (Digital Media Renderer) is shown.

Playing Internet Radio and Podcasts

Using the free app "Technics Audio Center", you can play an internet radio by setting this unit as a speaker for the internet radio. For details, visit:

www.technics.com/support/

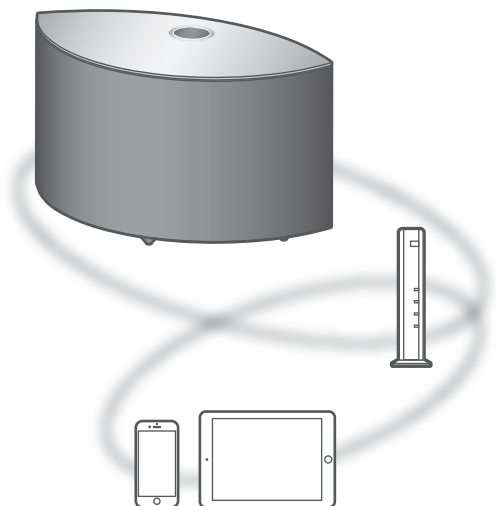

■ Preparation

- Complete the network settings. (⇒ 22)
 - Make sure that the network is connected to the Internet.
- Connect the device to the network currently used at home.

1 Start "Technics Audio Center" on your device (smartphone, tablet, etc.).

2 Select "Radio" / "Podcasts" from "Technics Audio Center".

3 Play back the music.

- "EQ" is displayed while playing back the internet radio station.
- "Podcasts" is displayed while playing back Podcasts.
- For operation details, refer to the operating instructions of "Technics Audio Center". For details, visit:
www.technics.com/support/
- Pressing [▶/||] mutes the sound while playing back the internet radio station. (To cancel the muting, adjust the volume, press again or turn the unit to standby.)

Using AirPlay

You can play back music stored on iOS device, etc. using AirPlay.

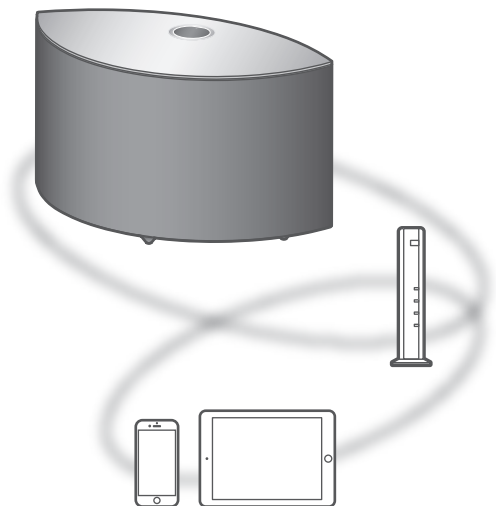

■ Preparation

- Complete the network settings. (⇒ 22)
- Connect the iOS device or PC to the same network as this unit.

1 (iOS device)

Start the “Music” (or iPod) app.

(PC)

Start “iTunes”.

2 Select “Technics-SC-C50-****” (“Technics-SC-C30-****”)*^{1,2} from the AirPlay icon (e.g.).

- If the device name is set on the “Google Home” app, the set name is displayed.

3 Start play.

- Check the volume settings before starting the playback.
- When AirPlay is used for the first time, the volume may be output at the maximum setting.
- The playback will start with a slight delay.

*1: “****” stands for a number that is unique to each set.

*2: The device name can be changed with the dedicated application “Technics Audio Center” (free of charge).

Playing back music using Spotify Connect

This unit is compatible with Spotify Connect for the online music service (Spotify). You can play music from the music streaming service of Spotify by operating your smartphone, tablet, etc.

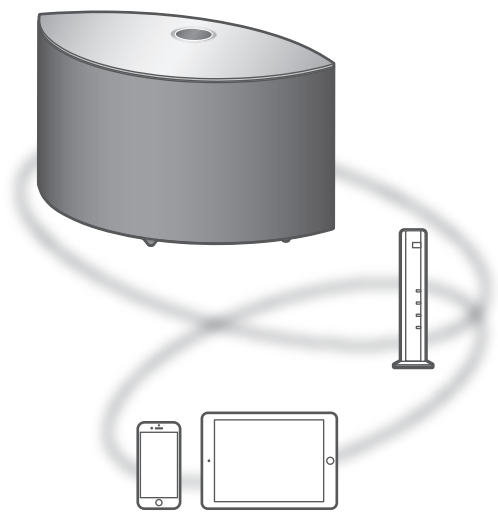

■ Preparation

- Complete the network settings. (⇒ 22)
 - Make sure that the network is connected to the Internet.
- Connect the device to be used to the network of this unit.

Use your phone, tablet or computer as a remote control for Spotify.

Go to spotify.com/connect to learn how

Note

- The device name of this unit will be displayed as "Technics-SC-C50-****" ("Technics-SC-C30-****")^{*1, 2}.
 - If the device name is set on the "Google Home" app, the set name is displayed.
 - Registration/subscription is required.
 - Services, icons, and specifications are subject to change.
- *1: "****" stands for a number that is unique to each set.
- *2: The device name can be changed with the dedicated application "Technics Audio Center" (free of charge).

Using TIDAL

You can play music from the music streaming service, TIDAL on this unit by operating the dedicated application "Technics Audio Center" (free of charge) on your smartphone, tablet, etc.

For details of TIDAL, visit the following website.

www.tidal.com

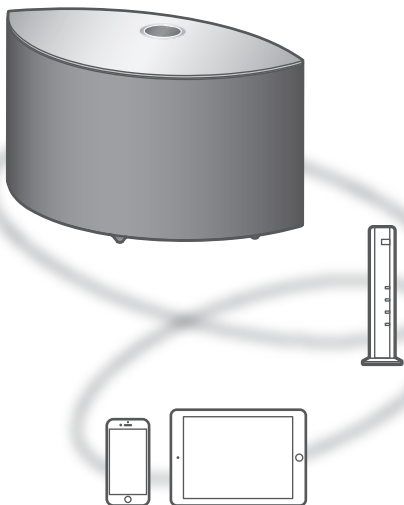

■ Preparation

- Install the latest "Technics Audio Center" on your device (smartphone, tablet, etc.). For details, visit: www.technics.com/support/
- Connect this unit and your device on which "Technics Audio Center" has been installed to the network connected to the Internet. For details, refer to their operating instructions.

- 1 Start "Technics Audio Center" on your device (smartphone, tablet, etc.).
- 2 Select "TIDAL" from "Technics Audio Center".

3 Follow the on-screen instructions and start playback.

(If you do not have an account, you need to register the account.)

- “◆◆◆” is displayed while playing back.
- Before using TIDAL, the account registration is required (paid service).
- For operation details, refer to the operating instructions of “Technics Audio Center”. For details, visit:
www.technics.com/support/

Note

- Depending on the country or region, playback may not be available.

Using Deezer

You can play music from the music streaming service, Deezer on this unit by operating the dedicated application “Technics Audio Center” (free of charge) on your smartphone, tablet, etc.

For details of Deezer, visit the following website.

www.deezer.com

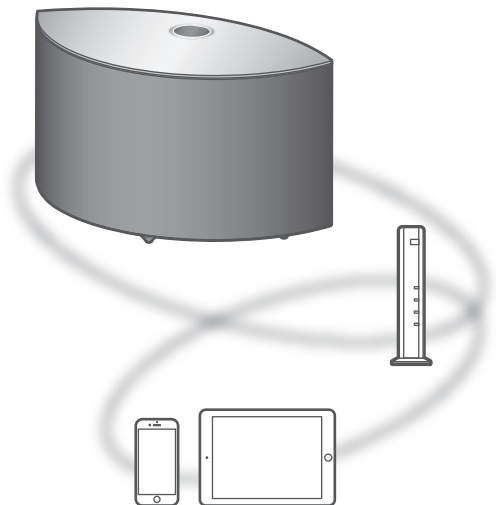

■ Preparation

- Install the latest “Technics Audio Center” on your device (smartphone, tablet, etc.). For details, visit: www.technics.com/support/
- Connect this unit and your device on which “Technics Audio Center” has been installed to the network connected to the Internet. For details, refer to their operating instructions.

- 1 Start “Technics Audio Center” on your device (smartphone, tablet, etc.).
- 2 Select “Deezer” from “Technics Audio Center”.

3 Follow the on-screen instructions and start playback.

(If you do not have an account, you need to register the account.)

- Before using Deezer, the account registration is required (paid service).
- For operation details, refer to the operating instructions of "Technics Audio Center". For details, visit:
www.technics.com/support/

Note

- Depending on the country or region, playback may not be available.

Settings

Using the favourite function.....	49
Registering your favourite station or playlist to this unit.....	49
Other settings	50
Firmware updates “F/W Update”	50
Setting up this unit from “Technics Audio Center”	51

[↶ Table of contents ...](#) 04

Using the favourite function

Registering your favourite station or playlist to this unit

You can register your favourite station or playlist (USB, Podcasts, etc.) and call up the station or playlist easily by pressing [★].

- You can register up to 9 favourite stations or playlists.
- The favourite function (registering/calling up/deleting) can also be set from the dedicated application “Technics Audio Center” (free of charge).

1 Press and hold [★] while the favourite station or playlist is played back.

- The unregistered number from 1 to 9 is automatically assigned.
- “Memorised” is displayed when the registration is completed. “Not Valid” is displayed if unable to register.

Note

- If a 10th station or playlist is added, “Full” is displayed. Delete the stations or playlists.

Calling up the favourite station or playlist

1 Press [★] repeatedly.

- Press repeatedly to switch to the registered number to be played back.

Note

- If the station or playlist cannot be found after the input source is switched, playback does not start or other music may play back.

Deleting the favourite station or playlist

1 Press [★] repeatedly to switch to the registered number to be deleted.

- Press repeatedly to switch to the registered number to be deleted. Select the station or playlist to be deleted.

2 Press [★] while pressing [•DIMMER / -INFO] when “★1-9” to be deleted is displayed.

- “Deleted” is displayed.

Other settings

Firmware updates "F/W Update"

Occasionally, Panasonic may release updated firmware for this unit that may add or improve the way a feature operates. These updates are available free of charge.

- For the update information, refer to the following website.
www.technics.com/support/firmware/

Downloading may take approx. 10 minutes or longer.

Do not disconnect the AC mains lead or turn this unit to standby while updating.

Do not disconnect the USB flash memory while updating.

- The progress is displayed as "Updating □ %" while updating. ("□" stands for a number.)

Note

- During the update process, no other operations can be performed.
- If there are no updates, "Firmware is Up To Date" is displayed. (No need to update it.)
- Updating the firmware may reset the settings of this unit.

Update via Internet

■ Preparation

- Connect this unit to the network. (⇒ 22)
 - Make sure that the network is connected to the Internet.

1 "Firmware update is available" is displayed if the firmware for this unit is available.

2 Press and hold [▶/III] for 5 seconds or longer to start the update.

- The progress is displayed as "Updating □ %" while updating. ("□" stands for a number.)
- When the update has finished successfully, "Success" is displayed. Turn this unit off and on.
- Firmware updating can also be set from the dedicated application "Technics Audio Center" (free of charge).

Note

- Downloading may take longer depending on the internet connection environment, etc.
- Firmware updating may automatically start after the network setting is complete (⇒ 22).

Update via USB flash memory

■ Preparation

- Download the latest firmware on the USB flash memory. For details, refer to the following website.

www.technics.com/support/firmware/

1 Connect the USB flash memory with new firmware.

2 Press [\rightarrow] repeatedly to select "USB".

3 Press and hold [\rightarrow] for 5 seconds or longer to start the update.

- The progress is displayed as "Updating □ %" while updating. ("□" stands for a number.)
- When the update has finished successfully, "Success" is displayed. Turn this unit off and on.

Note

- Downloading may take longer depending on the USB flash memory.

Setting up this unit from "Technics Audio Center"

You can configure the various settings of this unit using the dedicated app "Technics Audio Center" (free of charge). For details, visit:

www.technics.com/support/

Others

Troubleshooting.....	53
Heat buildup of this unit.....	53
Do you have the latest firmware installed?	53
To restore all the settings to the factory defaults.....	53
General	54
USB.....	55
Bluetooth®	56
Network.....	57
Spotify/TIDAL/Deezer/Internet Radio/ Podcasts	59
Messages.....	59
Playable media.....	62
USB.....	62
About Bluetooth®	63
Licenses.....	64
Specifications	66

[↶ Table of contents ...](#) 04

Troubleshooting

Before requesting service, make the following checks. If you are uncertain about some of the check points, or if the solutions indicated in the following guide do not resolve the issue, then consult your dealer for instructions.

Heat buildup of this unit

This unit becomes warm while in use.

- Be careful when touching the bottom of this unit because the bottom of this unit may be hot. For installation or unit care, disconnect the AC mains lead, wait for at least 3 minutes.

Do you have the latest firmware installed?

Panasonic is constantly improving the unit's firmware to ensure that our customers are enjoying the latest technology. (⇒ 50)

To restore all the settings to the factory defaults

When the following situations occur, reset the memory:

- There is no response when operating.
- You want to clear and reset the memory contents.

1 When the unit is on, press and hold [⏻/⏪] for 5 seconds or longer while pressing [•DIMMER / -INFO].

- The initialisation starts.

2 After the initialisation, this unit restarts.

General

The unit does not work.

Operations are not done properly.

- One of the unit's safety devices, etc. may have been activated.
 - ① Press [⏻/⏻] on the unit to switch the unit to standby.
 - If the unit does not switch to standby, press [⏻/⏻] on the unit for at least 5 seconds. The unit is forcibly switched to standby. Alternatively, disconnect the AC mains lead, wait for at least 3 minutes, then reconnect it.
 - ② Press [⏻/⏻] on the unit to switch on. (It may take some time for this unit to be turned on.)
 - If the unit still cannot be operated, consult the dealer.

A "humming" sound can be heard during playback.

- An AC mains lead of another device or fluorescent light is near the cables. Turn off other appliances, or keep them away from the cables of this unit.
- A strong magnetic field near a TV or other device may adversely affect the audio quality. Keep this unit away from such a location.
- The speakers may output noise when a device nearby is emitting powerful radio waves, such as when a mobile phone is on a call.

No sound.

- Check the volume of this unit and the connected device.
- Check to see if the cable connections to the input terminal of this unit and output terminal of the connected device are incorrect. If this is the case, turn this unit to standby and reconnect the cables correctly.
- Check to see if the correct input source is selected.
- Insert the plugs of the cables to be connected all the way in.
- Playback of multi-channel content is not supported.
- The digital audio input terminal of this unit can only detect linear PCM signals. For details, refer to the operating instructions of the device.

Playback does not start.

- Depending on your environment or connected devices, it may take some time.
- Check to see if the format of the file is supported. For supported formats, refer to "File format". (⇒ 70)

The unit turns to standby mode automatically.

- This unit incorporates a protection circuit to prevent damage caused by heat buildup. When you use this unit at a high volume level for a long period of time, it may turn off automatically. Wait for this unit to cool down before turning on this unit again. (For approximately 3 minutes)

The settings are reset to the factory defaults.

- Updating the firmware may reset the settings.

USB

The connected USB device becomes warm.

- The unit and USB device become warm when using for a long time. This is not a malfunction.

The USB drive or its contents cannot be read.

- The USB drive format or its contents is/are not compatible with the unit. (⇒ 62)
- The USB drive may not be read which has the files/folders with the long names, even if the number of the files/folders of the USB device doesn't reach a maximum number (⇒ 69).

No response when [▶/||] is pressed.

- Check to see if the format of the file is supported. (⇒ 71)
- Disconnect the USB device and then reconnect it. Alternatively, turn the unit to standby and on again.

Slow operation of the USB flash drive.

- Large file size or high memory USB flash drive takes longer time to read.
- It may take some time if there are a lot of files or folders on it.

Bluetooth®

Pairing cannot be completed.

- Check the Bluetooth® device condition.

The device cannot be connected.

- The pairing of the device was unsuccessful or the registration has been replaced. Try re-pairing the device. (⇒ 34)
- This unit might be connected to a different device. Disconnect the other device and try re-pairing the device.

The device is connected, but audio cannot be heard through this unit.

- For some built-in Bluetooth® devices, you have to set the audio output to this unit manually. Read the operating instructions for the device for details.

The sound is interrupted.

- The device is out of the 10 m communication range. Bring the Bluetooth® device closer to this system.
- Remove any obstacle between this system and the device.
- Other devices that use the 2.4 GHz frequency band (wireless router, microwaves, cordless phones, etc.) are interfering. Bring the Bluetooth® device closer to this system and distance it from the other devices.
- Switch the transmission mode of this unit, and it can be set by using the free app “Technics Audio Center”.

Network

Cannot connect to the network.

- Confirm the network connection and settings. (⇒ 22)
- If the network is set to be invisible, make the network visible while you set up the network for this unit or make a wired LAN connection.
 - To switch the Wi-Fi function between “On” and “Off”, press and hold the volume [—] on the top while pressing [•DIMMER / -INFO] on the rear of this unit for approx. 5 seconds.
- This system’s Wi-Fi security supports WPA2™. Your wireless router must therefore be WPA2™ compatible. For details on the security supported by your router and how to change the settings, please refer to the operating instructions or contact your internet service provider.
- Make sure that the multicast function on the wireless router is enabled.
- Depending on the router, WPS button may not work. Try another connection method. (⇒ 26)
- The wireless LAN environment or radio interference in your area may cause connection problem. In this case, try another connection method. If the problem persists, make a wired LAN connection. (⇒ 23)
- While the AC mains lead is disconnected, the LAN cable must be connected or disconnected.

Cannot select this system as the output speakers.

- Make sure that the devices are connected to the same network as this unit.
- Reconnect the devices to the network.
- Turn the wireless router off and then on.
- Turn this unit to standby and on, and then select this system as the output speakers again.

Cannot select this unit from the Chromecast-enabled apps.

- When using the Chromecast-enabled apps to play music on this unit, you need to set up a network connection using “Google Home” app. (⇒ 28)
- You may not select this unit from the video apps, etc.

Playback does not start.

The sound is interrupted.

- If using the 2.4 GHz band on the wireless router, simultaneous use with other 2.4 GHz devices, such as microwaves, cordless telephones, etc., may result in connection interruptions. Increase the distance between this unit and these devices.
 - If your wireless router supports 5 GHz band, try using the 5 GHz band.
- Do not place this system inside a metal cabinet, for it might block the Wi-Fi signal.
- If the playback stops, check the playback status on the device.
- Place this system closer to the wireless router.
- Press and hold [•DIMMER / -INFO] to display the network status, and press again to display the Wi-Fi signal strength level. The signal strength is shown as 3 (max) - 0 (not connected). Change the position or angle of your wireless router or this system, and see if the connection improves.
- If several wireless devices are simultaneously using the same wireless network as this unit, try turning off the other devices or reducing their wireless network usage.
- Reconnect the devices to the network.
- Turn the wireless router off and then on.
- Setting QoS function of your router to “disable” may resolve the sound interruptions.
- With some iOS and iTunes versions, it may not be possible to restart the AirPlay playback if the selector is changed (e.g. “AUX”) or this unit is in standby mode, during the AirPlay playback. In this case, select a different device from the AirPlay icon of the Music App or iTunes and then re-select this system as the output speakers. (⇒ 41)
- If the above solutions do not solve the problem, make a wired LAN connection for all connected devices which have LAN terminal (this unit, Network Attached Storage, media server, etc.). (⇒ 23)

Spotify/TIDAL/Deezer/ Internet Radio/Podcasts

Playback does not start.

The sound is interrupted.

- The station that does not broadcast cannot be played back (or it will be skipped).
- The internet radio station may not be played back depending on the broadcasting method or the network condition.
- Depending on the internet connection environment, the sound may be interrupted or it may take some time to play back.
- Service may not be available depending on the country or area.
- The services through Network Service are operated by their respective service providers, and service may be discontinued either temporarily or permanently without notice.

Messages

Auto Off

The unit turns to standby mode by the auto off function.

- Press [, etc. to cancel it.
- The auto off function can be changed with the dedicated application "Technics Audio Center" (free of charge).

Download Fail

- The firmware download has failed. Press any button to exit. Please try again later.
- The server cannot be found. Press any button to exit. Make sure that the network is connected to the internet.

Empty

The favourite station or playlist is not registered.

- Register the favourite station or playlist. (⇒ 49)

Fail

- Network connection is not complete. Try the setting again. (⇒ 22)
- Space Tune is not complete. Check the procedure of setting and retry the Space Tune setting. (⇒ 13)

Firmware update is available

- The firmware (free of charge) for this unit is available.
 - ① Press and hold [▶/■] for 5 seconds or longer.
 - The update automatically starts.
 - The progress is displayed as “Updating □ %” while updating. (“□” stands for a number.)
 - When the update has finished successfully, “Success” is displayed.
 - ② Turn this unit off after “Success” is displayed.
 - ③ Turn this unit on after 3 minutes.
- For the update information, refer to the following website.
www.technics.com/support/firmware/

Full

You cannot register the favourite stations or playlists more than 9.

- Delete the stations or playlists (⇒ 49).
- You can also delete the favourite station or playlist from the dedicated application “Technics Audio Center” (free of charge).

“F□□” (“□” stands for a number.)

- An abnormality has occurred. (If this unit detects an abnormality, the protection circuit is activated, and the power may be turned off automatically.)
 - Is this unit placed in an extremely hot place?
 - Wait a few seconds and then turn the unit on again. (The protection circuit will be deactivated.)

If the problem persists, write down the displayed number, disconnect the AC mains lead and consult your dealer.

Load Fail

- The firmware cannot be found on the USB flash memory.
- Download the latest firmware on the USB flash memory and try again. (⇒ 51)

No Device

No USB device is connected.

- Connect the USB device to be played. (⇒ 36)

The USB device cannot be played back.

- Check to see if the file system of USB device is playable. (⇒ 62)

Not Valid

- The function you have tried to use is not available with the current settings. Check the steps and settings.

Operate via App

The key operation of this unit is disabled.

- Make sure to operate from the dedicated application “Technics Audio Center” (free of charge) when you stream music files from the device on your network or online music services etc.

For details, visit:

www.technics.com/support/

Unlocked

- “OPT” is selected, but no device is connected. Check the connection with the device. (⇒ 33)
- The sampling frequency components, etc. of the audio signals are not input correctly.
 - For supported formats, refer to “File format” (⇒ 70)

USB Over Current Error

- USB device is drawing too much power. Disconnect the USB device and turn the unit to standby and on again. (⇒ 36)

Wired LAN

The LAN cable is connected to this unit.

- Disconnect the LAN cable when setting the wireless LAN connection. (⇒ 24)

Wi-Fi Setup

- Wireless LAN (Wi-Fi) setting may start when this unit is turned on. If you stop the Wi-Fi setting, press [↶]. To keep the Wi-Fi setting, start the “Google Home” app and follow the on-screen instructions. (⇒ 22, 24)

Playable media

USB

- This unit does not guarantee connection with all USB devices.
- FAT16, FAT32 and NTFS file systems are supported.
- This unit supports USB 2.0 high speed.
- USB devices may not be recognised by this unit when connected using the following:
 - a USB hub
 - a USB extension cable
- It is not possible to use USB card reader/writers.
- This unit cannot record music to a USB device.
- Not all files on the USB device may be read if there are some files not supported.
- About supported format, refer to “File format” (⇒ 70)

■ Folder and file structure

When pressing [▶/||] on this unit, the playback starts in the following order as shown.

Example:

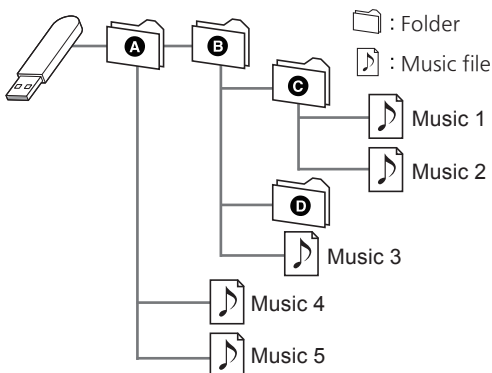

- For operation details, refer to the operating instructions of “Technics Audio Center”. For details, visit:
www.technics.com/support/

About Bluetooth®

Panasonic bears no responsibility for data and/or information that is compromised during a wireless transmission.

Frequency band used

- This system uses the 2.4 GHz frequency band.

Certification of this device

- This system conforms to frequency restrictions and has received certification based on frequency laws. Thus, a wireless permit is not necessary.
- The actions below are punishable by law in some countries:
 - Taking apart or modifying the system.
 - Removing specification indications.

Restrictions of use

- Wireless transmission and/or usage with all Bluetooth® equipped devices is not guaranteed.
- All devices must conform to standards set by Bluetooth SIG, Inc.
- Depending on the specifications and settings of a device, it can fail to connect or some operations can be different.
- This system supports Bluetooth® security features. But depending on the operating environment and/or settings, this security is possibly not sufficient. Transmit data wirelessly to this system with caution.
- This system cannot transmit data to a Bluetooth® device.

Range of use

- Use this device at a maximum range of 10 m. The range can decrease depending on the environment, obstacles or interference.

Interference from other devices

- This system may not function properly and troubles such as noise and sound jumps may arise due to radio wave interference if this system is located too close to other Bluetooth® devices or the devices that use the 2.4 GHz band.
- This system may not function properly if radio waves from a nearby broadcasting station, etc. is too strong.

Intended usage

- This system is for normal, general use only.
- Do not use this system near an equipment or in an environment that is sensitive to radio frequency interference (example: airports, hospitals, laboratories, etc.).

Licenses



The Wi-Fi CERTIFIED™ Logo is a certification mark of Wi-Fi Alliance®.

The Wi-Fi Protected Setup™ Logo is a certification mark of Wi-Fi Alliance®.



Use of the Works with Apple badge means that an accessory has been designed to work specifically with the technology identified in the badge and has been certified by the developer to meet Apple performance standards.

Apple and AirPlay are trademarks of Apple Inc., registered in the U.S. and other countries.

This product is compatible with AirPlay 2. iOS 11.4 or later is required.

Chromecast built-in

Google, Google Home and Chromecast built-in are trademarks of Google LLC.

The Google Assistant is not available in certain languages and countries.

Windows is a trademark or a registered trademark of Microsoft Corporation in the United States and other countries.

Windows Media and the Windows logo are trademarks or registered trademarks of Microsoft Corporation in the United States and/or other countries. This product is protected by certain intellectual property rights of Microsoft Corporation and third parties. Use or distribution of such technology outside of this product is prohibited without a license from Microsoft or an authorized Microsoft subsidiary and third parties.

Mac and OS X are trademarks of Apple Inc., registered in the U.S. and other countries.

The Bluetooth® word mark and logos are registered trademarks owned by Bluetooth SIG, Inc. and any use of such marks by Panasonic Corporation is under license. Other trademarks and trade names are those of their respective owners.

DSD is a trademark of Sony Corporation.

FLAC Decoder

Copyright (C) 2000, 2001, 2002, 2003, 2004, 2005, 2006, 2007, 2008, 2009 Josh Coalson

Redistribution and use in source and binary forms, with or without modification, are permitted provided that the following conditions are met:

- Redistributions of source code must retain the above copyright notice, this list of conditions and the following disclaimer.
- Redistributions in binary form must reproduce the above copyright notice, this list of conditions and the following disclaimer in the documentation and/or other materials provided with the distribution.
- Neither the name of the Xiph.org Foundation nor the names of its contributors may be used to endorse or promote products derived from this software without specific prior written permission.

THIS SOFTWARE IS PROVIDED BY THE COPYRIGHT HOLDERS AND CONTRIBUTORS "AS IS" AND ANY EXPRESS OR IMPLIED WARRANTIES, INCLUDING, BUT NOT LIMITED TO, THE IMPLIED WARRANTIES OF MERCHANTABILITY AND FITNESS FOR A PARTICULAR PURPOSE ARE DISCLAIMED. IN NO EVENT SHALL THE FOUNDATION OR CONTRIBUTORS BE LIABLE FOR ANY DIRECT, INDIRECT, INCIDENTAL, SPECIAL, EXEMPLARY, OR CONSEQUENTIAL DAMAGES (INCLUDING, BUT NOT LIMITED TO, PROCUREMENT OF SUBSTITUTE GOODS OR SERVICES; LOSS OF USE, DATA, OR PROFITS; OR BUSINESS INTERRUPTION) HOWEVER CAUSED AND ON ANY THEORY OF LIABILITY, WHETHER IN CONTRACT, STRICT LIABILITY, OR TORT (INCLUDING NEGLIGENCE OR OTHERWISE) ARISING IN ANY WAY OUT OF THE USE OF THIS SOFTWARE, EVEN IF ADVISED OF THE POSSIBILITY OF SUCH DAMAGE.

The Spotify Software is subject to third party licenses found here: <https://www.spotify.com/connect/third-party-licenses>.

Specifications

■ GENERAL

SC-C50

Power supply	AC 220 V to 240 V, 50/60 Hz
Power consumption	42 W
Power consumption in standby mode (Network Standby Off)	0.2 W
Power consumption in standby mode (Network Standby On with Wireless LAN)	2.0 W
Power consumption in standby mode (Network Standby On with Wired LAN)	2.0 W
Dimensions (W×H×D)	375 mm × 220 mm × 197 mm
Mass	Approx. 5.9 kg
Operating temperature range	0 °C to +40 °C
Operating humidity range	35 % to 80 % RH (no condensation)

SC-C30

Power supply	AC 220 V to 240 V, 50/60 Hz
Power consumption	30 W
Power consumption in standby mode (Network Standby Off)	0.2 W
Power consumption in standby mode (Network Standby On with Wireless LAN)	2.0 W
Power consumption in standby mode (Network Standby On with Wired LAN)	2.0 W
Dimensions (W×H×D)	315 mm × 190 mm × 191 mm
Mass	Approx. 4.5 kg
Operating temperature range	0 °C to +40 °C
Operating humidity range	35 % to 80 % RH (no condensation)

■ AMPLIFIER SECTION

SC-C50

Output power

Front speaker (L/R):
20 W + 20 W
(1 kHz, T.H.D. 1.0 %, 8 Ω , 20 kHz LPF)
Front speaker (Center):
20 W
(1 kHz, T.H.D. 1.0 %, 8 Ω , 20 kHz LPF)
Subwoofer:
40 W
(100 Hz, T.H.D. 1.0 %, 4 Ω , 20 kHz LPF)

SC-C30

Output power

Front speaker (L/R):
15 W + 15 W
(1 kHz, T.H.D. 1.0 %, 8 Ω , 20 kHz LPF)
Subwoofer:
30 W
(100 Hz, T.H.D. 1.0 %, 4 Ω , 20 kHz LPF)

■ SPEAKER SECTION

SC-C50

Front speaker (L/C/R)

Type	2 way, 2 speaker (Closed)
Woofers	6.5 cm × 1/ch, Cone type
Tweeter	1.6 cm × 1/ch, Dome type

Subwoofer

Type	1 way, 1 speaker (Bass reflex)
Subwoofer	12 cm × 1, Cone type

SC-C30

Front speaker (L/R)

Type	2 way, 2 speaker (Closed)
Woofers	6.5 cm × 1/ch, Cone type
Tweeter	1.6 cm × 1/ch, Dome type

Subwoofer

Type	1 way, 1 speaker (Bass reflex)
Subwoofer	12 cm × 1, Cone type

■ Bluetooth® SECTION

Bluetooth® system specification	Bluetooth® Ver.4.2
Wireless equipment classification	Class 2 (2.5 mW)
Supported profiles	A2DP, AVRCP
Supported codec	AAC, SBC
Frequency band	2.4 GHz band FH-SS
Operating distance	Approx. 10 m Line of sight*1

*1: Prospective communication distance

Measurement environment:

Temperature 25 °C/Height 1.0 m

Measure in "Mode1"

■ TERMINALS SECTION

USB	Type A Connector USB 2.0 High-Speed USB Mass Storage Class
Support Memory Capacity	2 TB (max)
Maximum number of folders (albums)	800
Maximum number of files (songs)	8000
File system	FAT16, FAT32, NTFS
USB port power	DC OUT 5 V 500 mA (max)
Ethernet interface	LAN (100BASE-TX/10BASE-T)
AUX Input	Stereo, ϕ 3.5 mm Jack
Digital Input	Optical digital input (Optical terminal)
Format support	LPCM

■ Wi-Fi SECTION

Standard	IEEE802.11a/b/g/n/ac
Frequency band	2.4 GHz band 5 GHz band
Security	WPA2™, Mixed mode WPA2™/ WPA™
WPS version	Version 2.0

- The WLAN feature of this product shall exclusively be used inside buildings.

■ File format

This unit supports the following file formats.

- This unit does not support the playback of copy-protected music files.
- Playback of all files in formats supported by this unit is not guaranteed.
- Playback of a file in a format not supported by this unit may cause choppy audio or noise. In such cases, check to see if this unit supports the file format.
- This unit does not support VBR (Variable Bit Rate) playback.
- Some of the connected devices or servers may be capable of converting files in formats not supported by this unit and output them. For details, refer to the operating instructions for your devices or servers.
- File information (sampling frequency, etc.) shown by this unit and playback software may differ from each other.

Optical digital input

Format support	Sampling frequency	Bit rate/ Number of quantisation bits
LPCM	32/44.1/48/ 88.2/96 kHz	16/24 bit

USB-A

File format	Extension	Sampling frequency	Bit rate/ Number of quantisation bits
MP3	.mp3	32/44.1/ 48 kHz	16 to 320 kbps
AAC	.m4a .aac	32/44.1/48/ 88.2/96 kHz	16 to 320 kbps
WAV	.wav	32/44.1/48/ 88.2/96/ 176.4/192/ 352.8/ 384 kHz	16/24/32 bit
FLAC	.flac	32/44.1/48/ 88.2/96/ 176.4/192/ 352.8/384 kHz	16/24 bit
AIFF	.aiff	32/44.1/48/ 88.2/96/ 176.4/192/ 352.8/384 kHz	16/24/32 bit
ALAC	.m4a	32/44.1/48/ 88.2/96/ 176.4/192/ 352.8/384 kHz	16/24 bit
DSD	.dff .dsf	2.8/5.6/ 11.2 MHz	

LAN (DMR)*

File format	Extension	Sampling frequency	Bit rate/ Number of quantisation bits
MP3	.mp3	32/44.1/ 48 kHz	16 to 320 kbps
AAC	.m4a .aac	32/44.1/48/ 88.2/96 kHz	16 to 320 kbps
WAV	.wav	32/44.1/48/ 88.2/96/ 176.4/192/ 352.8/384 kHz	16/24/32 bit
FLAC	.flac	32/44.1/48/ 88.2/96/ 176.4/192/ 352.8/384 kHz	16/24 bit
AIFF	.aiff	32/44.1/48/ 88.2/96/ 176.4/192/ 352.8/384 kHz	16/24/32 bit
ALAC	.m4a	32/44.1/48/ 88.2/96/ 176.4/192/ 352.8/384 kHz	16/24 bit
DSD	.dff .dsf	2.8/5.6/ 11.2 MHz	

*: Whether or not each music file can be played back over your network is determined by the network server even if the format of the file is listed above. For example, if you are using Windows Media Player 11, not all music files on the PC are playable. You can play back only those added to the library of Windows Media Player 11.

Note

- Specifications are subject to change without notice.
- Mass and dimensions are approximate.



Headquarter Address:
Panasonic Corporation
Kadoma, Osaka, Japan

Importer for Europe:
Panasonic Marketing Europe GmbH
Panasonic Testing Centre
Winsbergring 15, 22525 Hamburg, Germany

Panasonic Corporation

Web Site: <http://www.panasonic.com>

